

Flat Pattern view
SCALE: 1:2

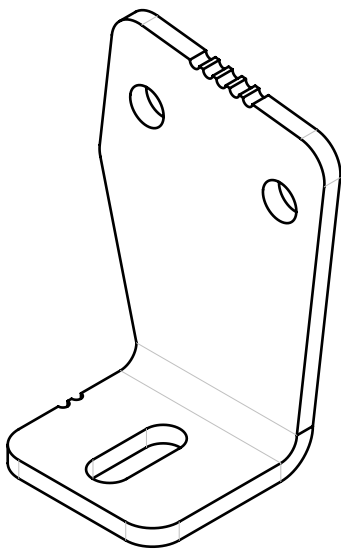
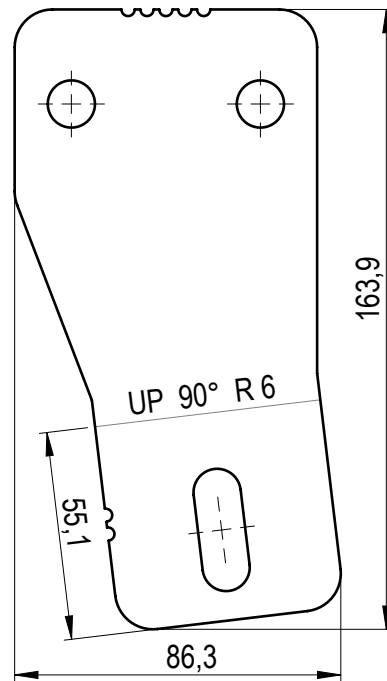
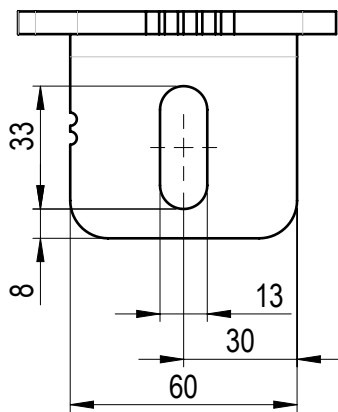

Other dimensions from .DXF file.

SHEET METAL INFORMATION	
Length, mm	165
Width, mm	81.7
Thickness, mm	6
Inside Bend Radius, mm	6
K-Factor	0.5
No. of Bends	1

	MATERIAL	S355J2	WEIGHT	0.491 Kg	DEBURR AND BREAK SHARP EDGES DO NOT SCALE DRAWING	REVISION	DATE	28.05.2025		
	SURFACE PROTECTION	HDG EN ISO 1461	MACHINING	ISO 2768 mK	THERMAL CUTTING	ISO 9013 221	WELDING	ISO 13920 BF	SCALE	1:2
NAME	SIGNATURE	PART NO.						105-09100-58		
Designed by	D. Dislers	DESCRIPTION						Right bracket 9M		
Drawn by	D. Dislers							SHEET 1/1		
Technical ref.										